



Huawei

AD9431DN-24X

Central AP

Datasheet



Product Overview

As ICT construction is taking place in various industries, such as the education, business, and enterprise, Wi-Fi technology has also found a wide application. Traditional settled AP or indoor distributed AP face the problems of poor signals or insufficient performance when providing coverage for dormitories, hotels, or offices. To resolve these problems, Huawei reforms the architecture of the traditional network and launches the innovative agile distributed Wi-Fi solution which can provide 1.167/1.267 Gbit/s high bandwidth for each room and comprehensive coverage without coverage holes. The agile distributed Wi-Fi solution is composed of the central AP AD9431DN-24X and remote units. The AD9431DN-24X can be deployed in the equipment room, weak-current well, or on the corridor. The remote units (RUs) are placed in rooms, and signals are transmitted over wired cables, without wall penetration loss, delivering high-quality wireless access services.



AD9431DN-24X

Typical Networking

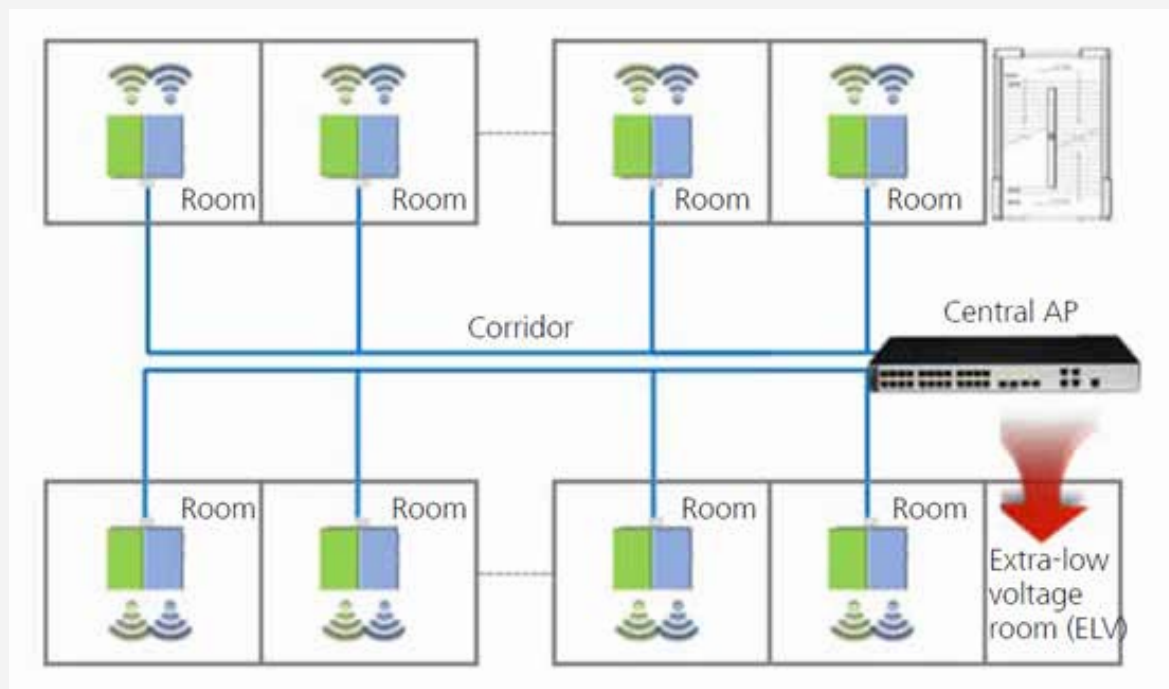

AD9431DN-24X..... //

- The AD9431DN-24X have 4 uplink 10 * GE interfaces.
- The downlink GE interfaces of the AD9431DN-24X support 24 PoE+ ports and can be directly connected to RUs.
- The AD9431DN-24X can be connected to 24 RUs directly and a maximum of 48 RUs through a switch.
- This solution is applicable to scenarios with a high density of rooms, such as dormitories, hotels, and offices.

Feature Description..... //

Easy to Manage

- The RUs do not occupy AC licenses. The AC only needs to manage AD9431DN-24X, so nearly 10,000 rooms require merely about 200 APs.

Flexible Deployment Modes Ensure Full Signal Coverage Without Coverage Holes

- AD9431DN-24X connects to indoor RUs through network cables without wall penetration loss and feeder loss, implementing high-quality signal coverage. The RUs can be flexibly mounted to a wall plate, wall, or ceiling.

Long-Distance Coverage

- Unlike the traditional distributed AP which allows for a maximum feeder length of 15 m, the AD9431DN-24X uses network cables to replace feeder cables and supports up to 100 m distance from the RUs. The network coverage range is therefore expanded by several times.

Link Disconnection Survival

- When the link between the AD9431DN-24X and AC disconnects, the AD9431DN-24X and RUs can maintain the current working states, preventing service interruptions of users and ensuring high-reliability transmission.

Hierarchical Processing Technology, High Wireless Forwarding Capability

- Huawei agile distributed Wi-Fi solution uses innovative hierarchical processing technology. AD9431DN-24X manages RUs in a centralized manner and concurrently forwards service traffic, while the RUs only process radio signals. The hierarchical design makes the network structure clearer and reduces the processing burden on the AD9431DN-24X and RUs, improving efficiency and optimizing the overall wireless forwarding performance.

Basic Specifications..... //**Table 1-1 Hardware specifications**

Item		AD9431DN-24X
Physical specifications	Dimensions (W x D x H)	442 mm x 310 mm x 43.6 mm
	Weight	4.3 kg
Power specifications	Power input	100 V AC to 24 V AC
	Power output	24-port standard PoE+ output
Environmental specifications	Operating temperature	0°C to +45°C
	Storage temperature	-40°C to +70°C
	Operating humidity	5% to 95% (non-condensing)
	Altitude	-60 m to +5,000 m
	Atmospheric pressure	53 kPa to 106 kPa
Performance specifications	Forwarding capability	24 Gbit/s
	Interface type	4 uplink 10 * GE interfaces 24 downlink GE electrical interfaces (PoE+ OUT)
	Maximum number of users	Maximum number of associated users: 4096 Maximum number of concurrent users: 1024
	Number of managed RUs	Directly connected RUs: 24(a maximum of 12 R250D-E in PoE out power supply mode) RUs connected through a switch: 48

Table 1-2 Software specifications

Item	Description
WLAN features	<ul style="list-style-type: none"> • Layer 2 network between the AD9431DN-24X and RUs • Direct connection between the AD9431DN-24X and RUs • Space time block code (STBC) • Beamforming • Low-density parity-check (LDPC) • Data unit aggregation, including A-MPDU (Tx/Rx) and A-MSDU (Rx only) • 802.11 Dynamic Frequency Selection (DFS) • Short Guard Interval (GI) in 20 MHz, 40 MHz, and 80 MHz modes • Priority mapping and packet scheduling based on a Wi-Fi Multimedia (WMM) profile to implement priority-based data processing and forwarding • Automatic and manual rate adjustment (the rate is adjusted automatically by default) • WLAN channel management and channel rate adjustment • Automatic channel scanning and interference avoidance • Service Set Identifier (SSID) hiding, support for SSIDs in Chinese • Signal Sustain Technology (SST) • Unscheduled Automatic Power Save Delivery (U-APSD) • Control and Provisioning of Wireless Access Points (CAPWAP) in Fit AP mode • Automatic login in Fit AP mode • Extended Service Set (ESS) • Multi-user CAC
Network features	<ul style="list-style-type: none"> • Compliance with IEEE 802.3ab • Auto-negotiation of the rate and duplex mode; automatic switchover between the Media Dependent Interface (MDI) and Media Dependent Interface Crossover (MDI-X) • SSID-based VLAN assignment • 4,094 VLAN IDs (1 to 4,094) • Management channel of the AP uplink port in tagged and untagged mode • DHCP client, obtaining IP addresses through DHCP • Tunnel forwarding and direct forwarding • STA isolation in the same VLAN • Multicast Domain Name Service (mDNS) gateway protocol: supports AirPlay and AirPrint service sharing between users of different VLANs • Access control lists (ACLs) • Link Layer Discovery Protocol (LLDP) • Uninterrupted service holding upon CAPWAP link disconnection • Unified authentication on the AC in Fit AP mode • AC dual-link backup in Fit AP mode • IPv6 in Fit AP mode

Item	Description
QoS features	<ul style="list-style-type: none"> • Priority mapping and packet scheduling based on a WMM profile to implement priority-based data processing and forwarding • WMM parameter management for each radio • WMM power saving • Priority mapping for upstream packets and flow-based mapping for downstream packets • Queue mapping and scheduling • User-based bandwidth limiting • Adaptive bandwidth management (the system dynamically adjusts bandwidth based on the number of users and radio environment to improve user experience) • Support for Microsoft Lync APIs and high voice call quality through Lync API identification and scheduling • Airtime scheduling
Security features	<ul style="list-style-type: none"> • Open system authentication • WEP authentication/encryption • WPA/WPA2-PSK authentication and encryption • WPA/WPA2-802.1x authentication and encryption • WPA-WPA2 authentication • WAPI authentication and encryption • WIDS including rogue AP and STA detection, attack detection, STA/AP blacklist and whitelist • 802.1x authentication, MAC address authentication, and Portal authentication • 802.11w Protected Management Frames (PMFs) • Application identification
Maintenance features	<ul style="list-style-type: none"> • Unified management and maintenance on the AC in Fit AP mode • Plug-and-Play (PnP): automatic ally going online and loading configurations in Fit AP mode • Batch upgrade in Fit AP mode • Telnet • STelnet using SSH v2 • SFTP using SSH v2 • Local AP management through the serial interface • Real-time configuration monitoring and fast fault location using the NMS • System status alarm

Item	Description
BYOD	<p>NOTE</p> <p>The AP supports bring your own device (BYOD) only in Fit AP mode</p> <ul style="list-style-type: none"> Identifies the device type according to the Organizationally Unique Identifier (OUI) in the MAC address. Identifies the device type according to the User Agent (UA) information in an HTTP packet Identifies the device type according to DHCP options. The RADIUS server delivers packet forwarding, security, and QoS policies according to the device type carried in the RADIUS authentication and accounting packets.
Location service	<p>NOTE</p> <ul style="list-style-type: none"> The AP supports the locating service only in Fit AP mode. Locates tags manufactured by AeroScout or Ekahau. Locates Wi-Fi terminals. Works with eSight to locate rogue devices.
Spectrum analysis	<p>NOTE</p> <p>The AP supports spectrum analysis only in Fit AP mode.</p> <ul style="list-style-type: none"> Identifies interference sources such as baby monitors, Bluetooth devices, digital cordless phones (at 2.4 GHz frequency band only), wireless audio transmitters (at both the 2.4 GHz and 5 GHz frequency bands), wireless game controllers, and microwave ovens. Works with Huawei eSight to locate and perform spectrum analysis on interference sources.

Table 1-3 Standards Compliance

Item	Description
Safety standards	<p>UL 60950-1</p> <p>IEC 60950-1</p> <p>EN 60950-1</p> <p>GB 4943</p>
Radio standards	<p>ETSI EN 300 328</p> <p>ETSI EN 301 893</p> <p>China's SRRC document [2002] No. 227</p> <p>China's SRRC document [2002] No. 277</p> <p>China's SRRC document [2002] No. 353</p> <p>China's SRRC document [2012] No. 620</p>
EMC standards	<p>EN 301 489-1</p> <p>EN 301 489-17</p> <p>ETSI EN 60601-1-2</p> <p>ICES-003</p> <p>YD/T 1312.2-2004</p> <p>ITU k.21</p> <p>GB 9254</p> <p>GB 17625.1</p> <p>EN 55022</p> <p>IEC61000-4-6</p> <p>IEC61000-4-2</p>

Item	Description
IEEE standards	IEEE 802.11a/b/g IEEE 802.11n IEEE 802.11ac IEEE 802.11h IEEE 802.11d IEEE 802.11e IEEE 802.11k IEEE 802.11u IEEE 802.11v IEEE 802.11w
Security standards	802.11i, Wi-Fi Protected Access 2(WPA2), WPA 802.1x Advanced Encryption Standards (AES), Temporal Key Integrity Protocol (TKIP), and EAP Type (s)
Environmental standards	ETSI 300 019-2-1 ETSI 300 019-2-2 ETSI 300 019-2-3 ETSI 300 019-1-1 ETSI 300 019-1-2 ETSI 300 019-1-3
EMF	CENELEC EN 62311 CENELEC EN 50385 OET65 RSS-102
RoHS	Directive 2002/95/EC & 2011/65/EU
Reach	Regulation 1907/2006/EC
WEEE	Directive 2002/96/EC & 2012/19/EU

Professional Service and Support

Huawei WLAN planning tools deliver expert network design and optimization services using the most professional simulation platform in the industry. Backed by fifteen years of continuous investment in wireless technologies, extensive network planning and optimization experience, and rich expert resources, Huawei helps customers:

- Design, deploy, and operate a high-performance network that is reliable and secure.
- Maximize return on investment and reduce operating expenses.



More Information

For more information, please visit <http://e.huawei.com/en/> or contact your local Huawei office.

Copyright © Huawei Technologies Co., Ltd. 2017. All rights reserved.

No part of this document may be reproduced or transmitted in any form or by any means without prior written consent of Huawei Technologies Co., Ltd.

Trademark Notice

 HUAWEI, and  are trademarks or registered trademarks of Huawei Technologies Co., Ltd. Other trademarks, product, service and company names mentioned are the property of their respective owners.

General Disclaimer

The information in this document may contain predictive statements including, without limitation, statements regarding the future financial and operating results, future product portfolio, new technology, etc. There are a number of factors that could cause actual results and developments to differ materially from those expressed or implied in the predictive statements. Therefore, such information is provided for reference purpose only and constitutes neither an offer nor an acceptance. Huawei may change the information at any time without notice.

HUAWEI TECHNOLOGIES CO.,LTD.
Huawei Industrial Base
Bantian Longgang
Shenzhen 518129,P.R.China
Tel: +86 755 28780808

www.huawei.com